

# EX - LED EXIT

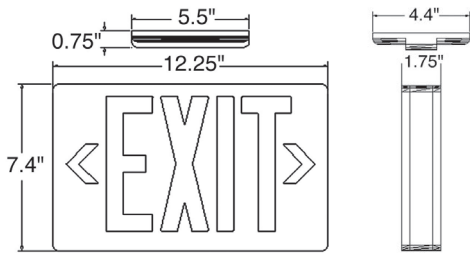

## DIMENSIONS



EX

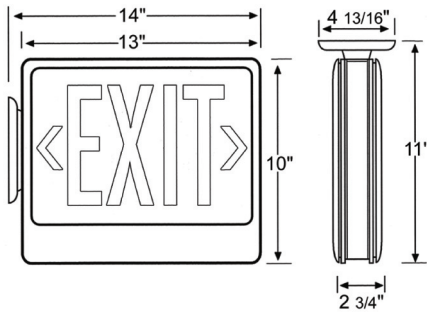

EX with remote capacity

## HOUSING

- Two sizes: Standard & Remote
- Injection Molded UL924 VO Flame Rated Thermoplastic
- Snap together Design
- Universal Face Design
- Damp Location Rated
- Replaceable Chevron Arrows
- Available in White or Black

## ILLUMINATION

- L.E.D. source - available in long life, high output red or green
- Fully illuminated 6" letters with 3/4" stroke
- Low energy consumption with 2 watt red or 1 watt green LEDs

## ELECTRONICS

- 120/277 Dual voltage
- Overload & short circuit protection
- Voltage surge & brown-out protection
- Solid-state constant current charger

## BATTERY

- 6 Volt Ni-Cad Battery Standard on Non-Remote Units
- 6 Volt Lead Calcium Standard on Remote Capable Units
- Remote Capable Capacity up to 27 watts Optional.
- All Battery Options Fully Contained within the Fixture

## MOUNTING

- Universal Mount with Canopy
- Universal J-Box Mounting Pattern

## SELF-TEST/SELF-DIAGNOSTIC OPERATION (SD2)

- The circuit continuously monitors the operating condition of the AC power, battery supply voltage, emergency lamp continuity and charging circuit.
- If a failure is detected, visual status will occur immediately via the multi-colored LEDs. LED indicator(s) will illuminate until fault has been corrected.
- The SD2 also monitors the transfer circuit as well as performing automatic code compliant testing. The self-test will operate the equipment in emergency mode five minutes every 28 days. Also, a 90 minute full-function test is performed every six months.

## CODE CONFORMANCE & STANDARDS

- UL 924 on Emergency Units
- N.E.C.
- OSHA
- N.F.P.A. Life Safety Code 101

## ORDERING INFORMATION

TYPICAL ORDER EXAMPLE: **EX R U WB WH SD2**

Prefix	Letter Color	Number of Faces	Battery	Housing	Options
EX - Exit Sign	R - Red G - Green	U - Universal (includes 2 face plates, back plate and mounting canopy)	<b>LB</b> -Less Battery <b>WB</b> -With Battery	WH - White BK - Black	SD2-Self Test / Self Diagnostics (not available on remote capable units) R12-12 Watts Remote Capacity R27-27 Watts Remote Capacity WG- (*) see wire guard chart PK1-1' Pendant Kit PK2- 2' Pendant Kit PE12- 12" Pendant Extension FL-Flasher AA-Audible Alarm FA-Flasher / Audible Alarm DLT-Down Light IF-Alarm Interface & Flasher IFA-Alarm Interface / Flasher / Audible Alarm VL-Vandal Lens SF-Special Sign Face 2CI- 2 Circuit Input (not available on remote capable units) PG-polycarbonate guard (see chart)

04/22/10

Project Name \_\_\_\_\_ Fixture Type \_\_\_\_\_

Catalog # \_\_\_\_\_