

INSTALLATION AND ASSEMBLY INSTRUCTIONS

CHALLENGER™ II (CH2H & CH2V) UPSWEEP ARM KIT

STOP!!! IF YOU HAVE SHEET METAL LUMINAIRES, PROCEED WITH INSTRUCTIONS BELOW. IF YOU HAVE CAST LUMINAIRES, SEE OTHER SIDE!

TOOLS REQUIRED: Socket wrench, 3/4" and 9/16" sockets, 6" socket extension, Phillips-head screwdriver, fish tape, duct tape, clean cloth.

PARTS IN KIT: Arm, 2 boot castings, 2 gaskets, hardware kit.

ASSEMBLING BOOT CASTING TO POLE

1. The pole must have two 9/16" holes and one 3/4" hole (See Fig. 1).
2. There are 2 boot castings, one has a stud protruding out mounting side. With this boot casting in hand, round portion pointing upward, peel backing off one gasket and line up with holes in casting. Line up holes of casting with holes in pole. Using ratchet with 6" extension and 3/4" socket, thread top captive bolt into nut plate (supplied with hardware kit). Insert 1/2" x 2-1/4" bolt and lock washer into lower bracket hole, and thread into nut plate (See Fig. 2). Repeat for T90, D180, TN120, D70, and Quad.

3. Thread a 3/8" bolt into threaded hole on top of boot casting, so that 7-10 threads are still showing. Place arm over boot casting, sliding arm until it bottoms out on exposed 3/8" bolt threads.

Note: Make sure holes in arm are facing up!

(See Fig. 2-3).

4. Locate hole in bottom of boot casting, on round portion near arm. Starting at this point, run fish tape through arm, out top.

Note: Do not run fish tape through boot casting mounting holes. Hook fish tape to arm end at approximately 2 o'clock position looking into arm end (See Fig.3).

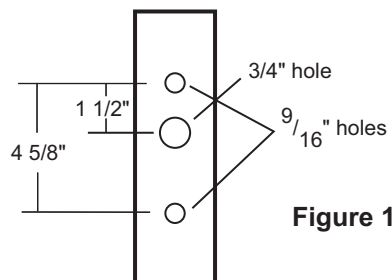

Figure 1

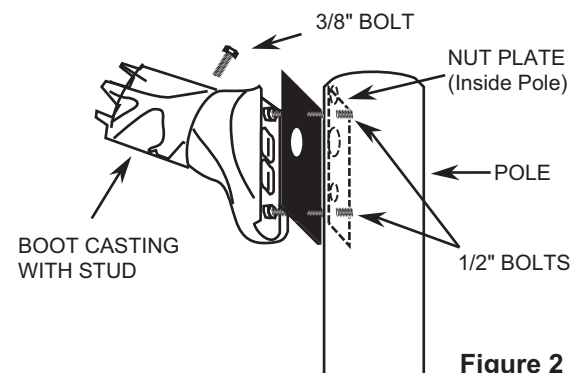

Figure 2

PREPARING LUMINAIRE

Note: Remove outer carton and top partitions and bend box end down to gain access inside luminaire arm.

1. Loosen two door screws with Phillips-head screwdriver. Note: Screws are captive, do not remove completely! Swing door open (See Fig. 4).
2. Loosen ballast cover screws (do not remove screws). Remove ballast cover and place aside.
3. With the other boot casting in hand, round portion facing upward, peel backing off gasket and line up with holes in casting. Route wire harness of luminaire through wireway hole in boot casting. Align two 9/16" holes in boot casting with luminaire holes. From inside luminaire, using 1/2" x 2-1/4" bolt and flat washer supplied in hardware kit, insert bolt and washer through one mounting bolt hole. Attach boot casting to luminaire using locking flange-type nut. Repeat procedures for other bolt and washer.

Note: You will need to insert one flange-type nut onto the 3/4" socket, then onto the 6" socket extension, to reach the top bolt inside boot casting.

Thread a 3/8" bolt into threaded hole on top of boot casting, so that 7-10 threads are still showing (See Fig. 5).

Repeat for each luminaire.

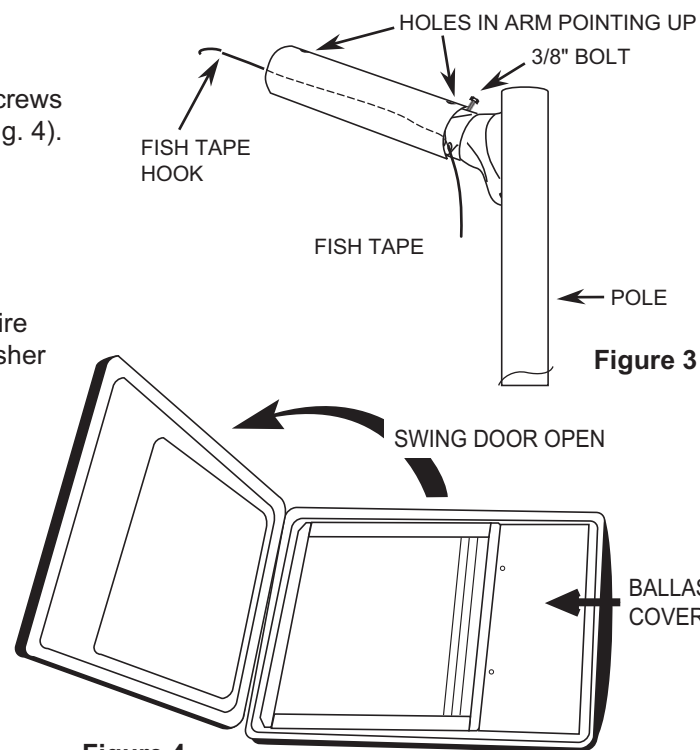

Figure 4

FINAL ASSEMBLY

1. Pick up luminaire/boot casting assembly, and flip so the boot casting is pointing towards the ground. Place round portion of boot casting into open end of arm, allowing the exposed bolt threads to rest on arm.
2. Pull fish tape further out arm. Using duct tape, secure end of wire harness to fish tape hook. Pull harness through arm from pole end. Remove duct tape, and feed wire harness through boot casting hole, through pole, and exit out top of pole. Make wiring connections. Press cap onto pole top.
3. Remove the (2) 3/8" bolts from the top hole in boot castings. Slide assembly together, so the arm ends bottom out against the boot casting ends. Rethread bolts in same holes with lockwashers, this time tightening with socket wrench and 9/16" socket (See Fig. 6).

Note! Make sure 3/8" arm bolts are on top of arm, not bottom! Assembly will sag if bolts are on bottom!

FINISHING UP

1. Make proper ballast connections, per the supply voltage and wiring diagram supplied on ballast and luminaire installation instructions. Re-install ballast cover and tighten screws.
2. Install lamp in socket, by first tightening, then loosening, and again tightening lamp. This ensures a proper connection. Wipe lamp and reflector with clean, dry cloth.
3. Swing door closed, and tighten two screws.
4. Make supply wiring connections at handhole in pole (See Fig. 7).

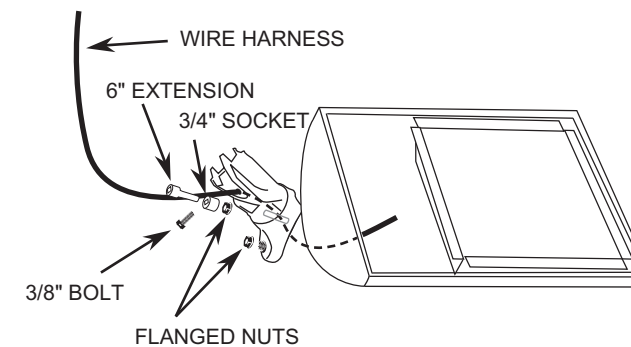

Figure 5

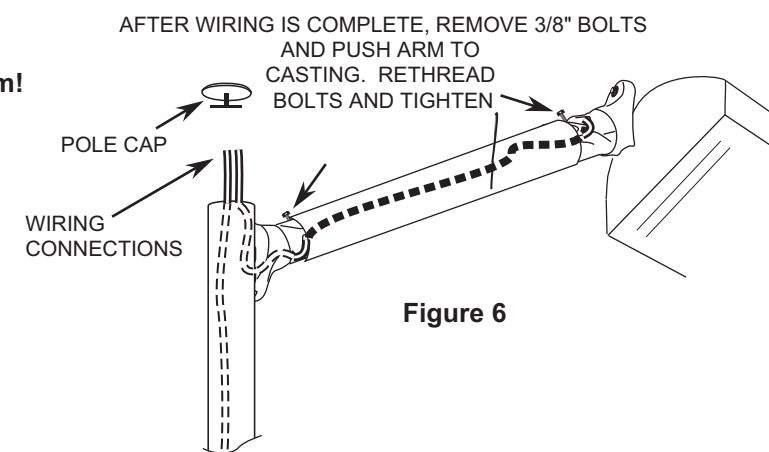

Figure 6

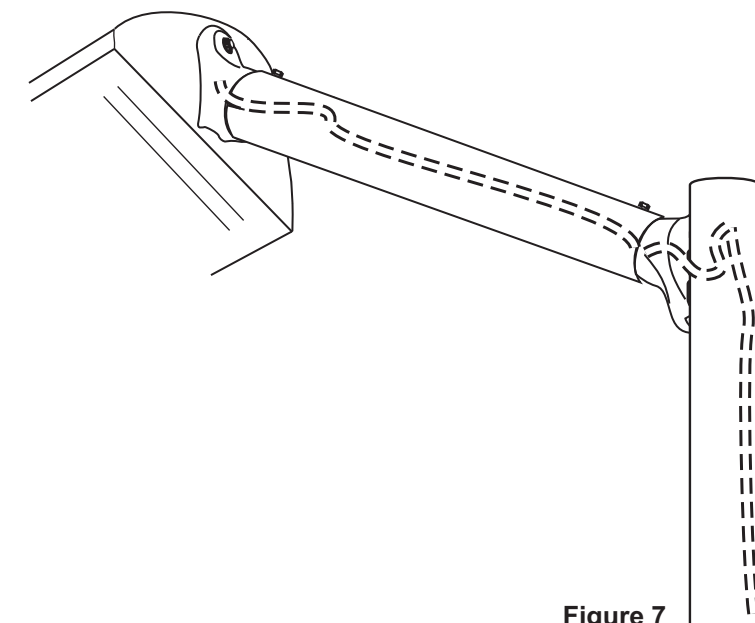

Figure 7



Installation Questions?
Call LSI Field Service Department at:
1-800-436-7800 Ext. 3300 Fax: (513)793-0147

INSTALLATION AND ASSEMBLY INSTRUCTIONS

CHALLENGER™ & PATRIOT UPSWEEP ARM KIT

STOP!!! IF YOU HAVE CAST LUMINAIRES, PROCEED WITH INSTRUCTIONS BELOW. IF YOU HAVE SHEET METAL LUMINAIRES, SEE OTHER SIDE!

TOOLS REQUIRED: Socket wrench, 3/4" and 9/16" sockets, 6" socket extension, Phillips-head screwdriver, 1/4" Allen-head socket, torque wrench, fish tape, duct tape, clean cloth.
PARTS IN KIT: Arm, 2 boot castings, 2 gaskets, various fasteners.

ASSEMBLING BOOT CASTING TO POLE

1. The pole must have two 9/16" holes and one 3/4" hole (See Fig. 1).
2. There are 2 boot castings, one has a stud protruding out mounting side. With this boot casting in hand, round portion pointing upward, peel backing off one gasket and line up with holes in casting. Line up holes of casting with holes in pole. Using ratchet with 6" extension and 3/4" socket, thread top captive bolt into nut plate (supplied with fixture hardware kit). Insert 1/2" x 2" bolt and lock washer into lower bracket hole, and thread into nut plate (See Fig. 2). Repeat for T90, D180, TN120, D70, and Quad.

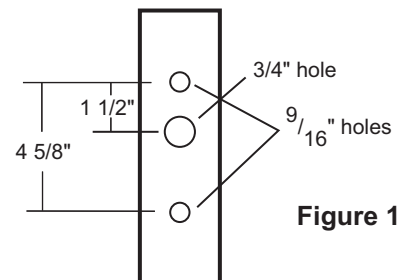

Figure 1

3. Thread a 3/8" bolt into threaded hole on top of boot casting, so that 7-10 threads are still showing. Place arm over boot casting, sliding arm until it bottoms out on exposed 3/8" bolt threads.

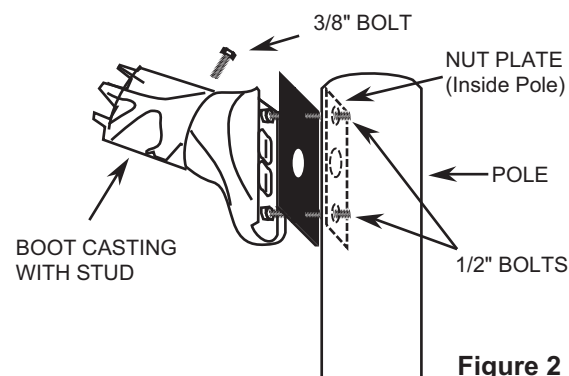

Figure 2

Note: Make sure holes in arm are facing up! (See Fig. 2-3).

4. Locate hole in bottom of boot casting, on round portion near arm. Starting at this point, run fish tape through arm, out top.

Note: Do not run fish tape through boot casting mounting holes. Hook fish tape to arm end at approximately 2 o'clock position looking into arm end (See Fig.3).

PREPARING LUMINAIRE

Note: Remove outer carton and top partitions and bend box end down to gain access inside fixture arm.

1. To lighten fixture for easier handling, loosen two door screws with Phillips-head screwdriver. Note: These screws are captive, do not remove completely! Swing door open, and remove door from hinges. Set door aside (See Fig. 4).
2. Remove black ballast plate by squeezing 2 spring clips together. Swing plate upward, and remove plate from hinge bracket.
3. With the other boot casting in hand, round portion facing upward, peel backing off gasket and line upward, peel backing off gasket and line up with holes in casting. Align two 9/16" holes in boot casting with fixture holes. Using studs supplied with fixture hardware kit, thread a locking type flange nut (supplied with arm hardware kit) onto stud with no more than 1/8" protruding past nut. **Note: Do not use nuts, flat washers or lock washers supplied with luminaire hardware kit.** From inside fixture, insert stud with nut through one mounting bolt hole. Attach boot casting to fixture using locking flange type nut. Repeat procedures for other stud. **Note: You will need to insert one flanged nut onto the 3/4" socket, onto the 6" socket extension, to reach the top bolt inside boot casting.** Thread a 3/8" bolt into threaded hole on top of boot casting, so that 7-10 threads are still showing (See Fig. 5). Repeat for each luminaire.

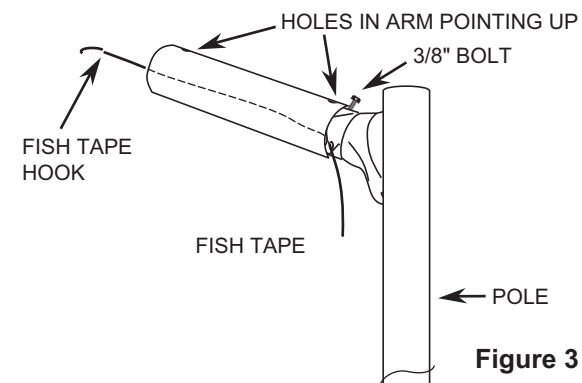

Figure 3

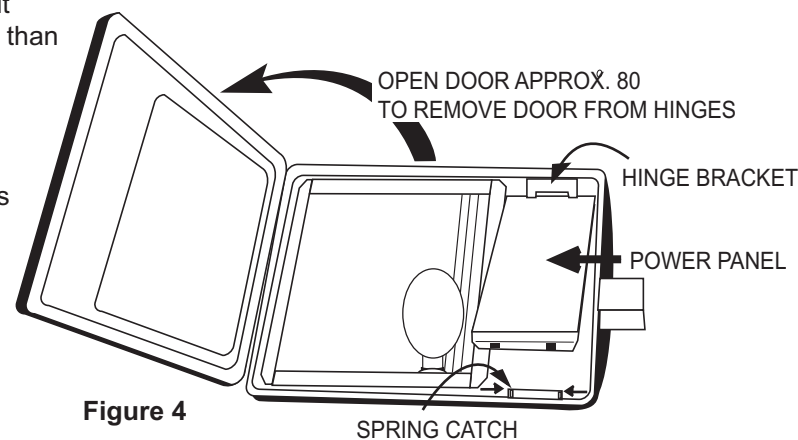

Figure 4

FINAL ASSEMBLY

1. Pick up fixture/boot casting assembly, and flip so the boot casting is pointing towards the ground. Place round portion of boot casting into open end of arm, allowing the exposed bolt threads to rest on arm.
2. Pull fish tape further out arm. Using duct tape, secure end of pigtail wires to fish tape hook. Pull wires through arm from pole end. Remove duct tape, and feed wires through boot casting hole, through pole, and exit out top of pole. Make wiring connections. Press cap onto pole top.
3. Remove the two 3/8" bolts from the top hole in boot castings. Slide assembly together, so the arm ends bottom out against the boot casting ends. Rethread bolts in same holes with lockwashers, this time tightening with socket wrench and 9/16" socket (See Fig. 6).

NOTE: Pigtail wiring supplied by others. Recommend 7 feet, 14 AWG 150°C wire. See wiring diagram supplied with fixture installation instructions.

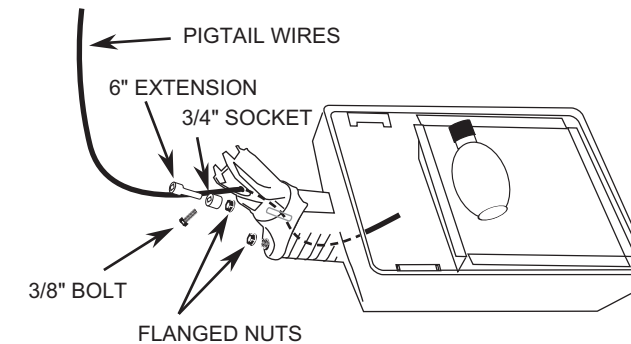

Figure 5

Note! Make sure 3/8" arm bolts are on top of arm, not bottom! Assembly will sag if bolts are on bottom!

FINISHING UP

1. Hang ballast plate back onto hinge bracket. Make proper ballast connections, per the supply voltage and wiring diagram supplied on ballast and fixture installation instructions. Swing plate up to spring clips. Push up until clips protrude through two slots in plate end. **Note: Do not pinch wiring!**
2. Install lamp in socket, by first tightening, then loosening, and again tightening lamp. This ensures a proper connection. Wipe lamp with clean, dry cloth.
3. Hang door onto fixture hinges. Swing door closed, and tighten two screws. Alternate tightening them; this ensures a water-tight and bug-free installation.
4. Make supply wiring connections at handhole in pole (See Fig. 7).

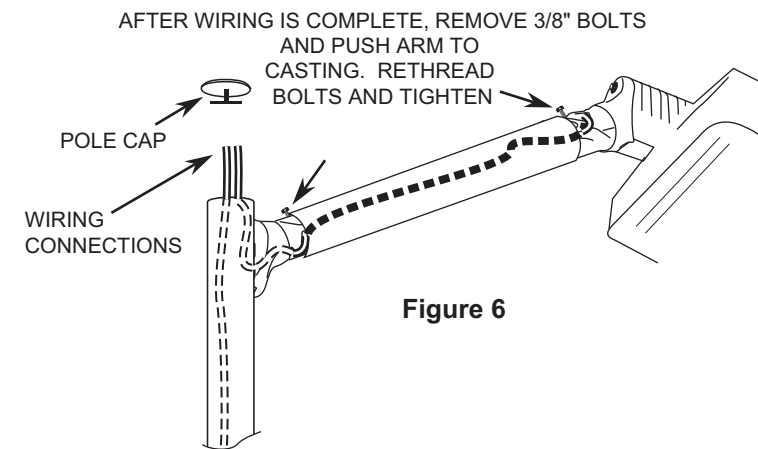

Figure 6

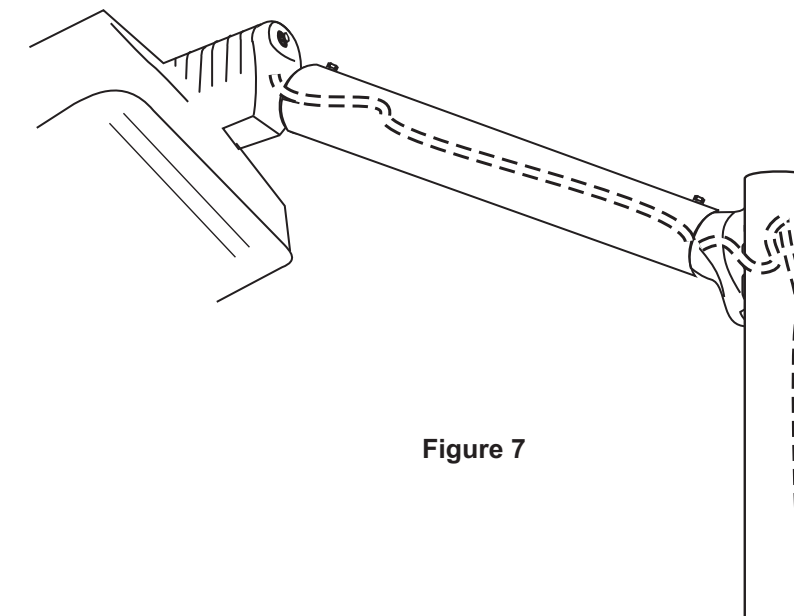

Figure 7



Installation Questions?
 Call LSI Field Service Department at:
 1-800-436-7800 Ext. 3300 Fax: (513)793-0147