

GLARE SHIELD INSTALLATION INSTRUCTIONS CH2H / CH2V CHALLENGER® II SERIES LUMINAIRE

STOP!!! FOR SHEET METAL LUMINAIRES PROCEED BELOW. FOR CAST LUMINAIRES, TURN SHEET OVER!

SHIELD POSITIONING

Glare shield should be placed on side that will best block light from the area to be shielded, and will allow maximum reflector performance.

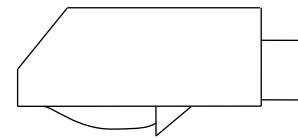

TYPE II

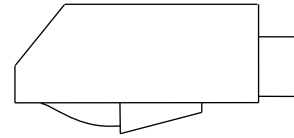

ALL OTHER TYPES

The drawings below show location of shields for best performance of reflector. Whenever possible, glare shields should be placed in the indicated positions. See Figure 1.

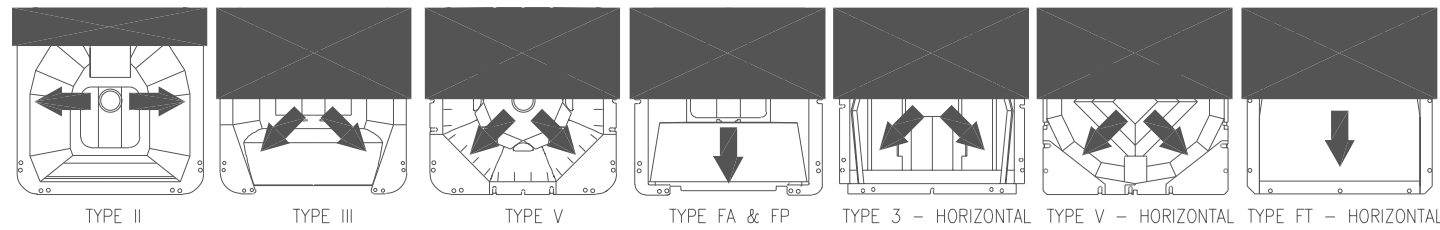

FIGURE 1

SHIELD INSTALLATION

1. Position shield on housing and mark drilling locations - using drill points when possible - through slotted holes in shield. See Figure 2.
2. Remove shield and drill 3/8" diameter holes through door (4 places).
3. Insert well-nut into each hole.
4. Position and install shield using 10-32 screws and lock washers. Tighten screws until snug.
5. Install hole plugs.

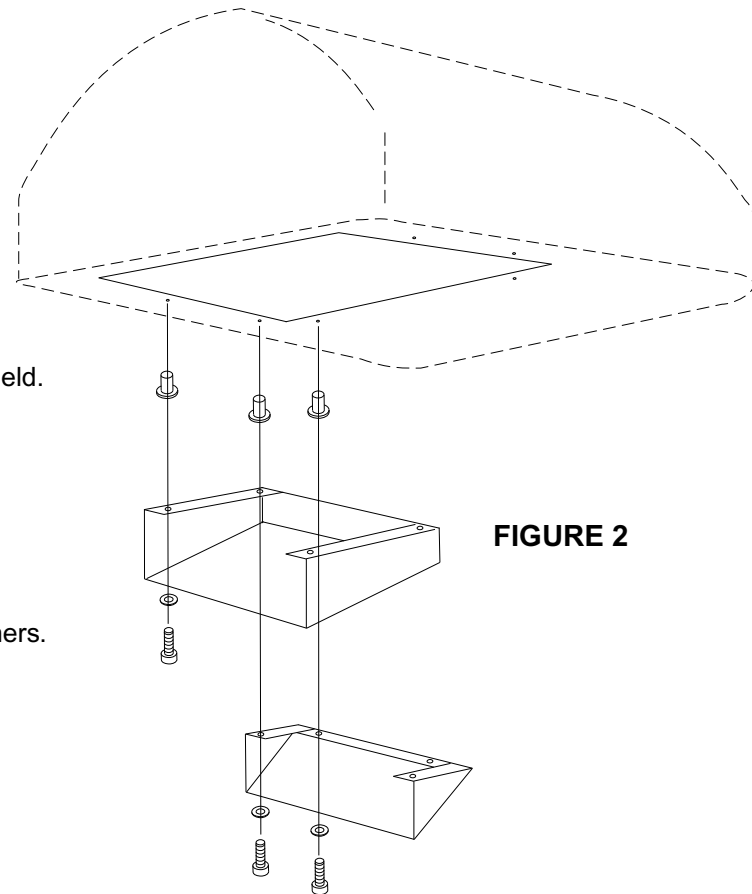

FIGURE 2

GLARE SHIELD INSTALLATION INSTRUCTIONS CHH / CHV CHALLENGER® SERIES LUMINAIRE

STOP!!! FOR CAST LUMINAIRES PROCEED BELOW. FOR SHEET METAL LUMINAIRES, TURN SHEET OVER!

SHIELD POSITIONING

Glare shield should be placed on side that will best block light from the area to be shielded, and will allow maximum reflector performance.

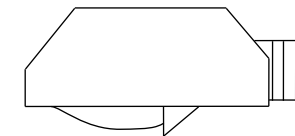

TYPE II

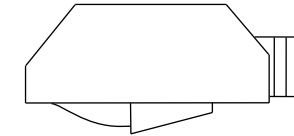

TYPE III & TYPE FA/FP

The drawings below show location of shields for best performance of reflector. Whenever possible, glare shields should be placed in the indicated positions. See Figure 1.

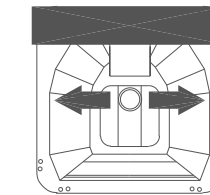

TYPE II

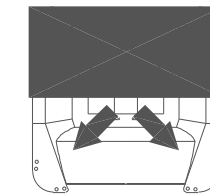

TYPE III

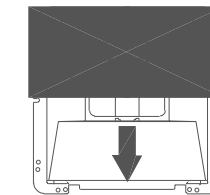

TYPE FA & FP

FIGURE 1

SHIELD INSTALLATION

1. Position shield on housing and mark drilling locations - using drill points when possible - through slotted holes in shield. See Figure 2.
2. Remove shield and drill 5/32" diameter holes through door (4 places).
3. Position and install shield using 10-16 self-tapping screws and lock washers. Tighten screws until snug.
4. Install hole plugs.

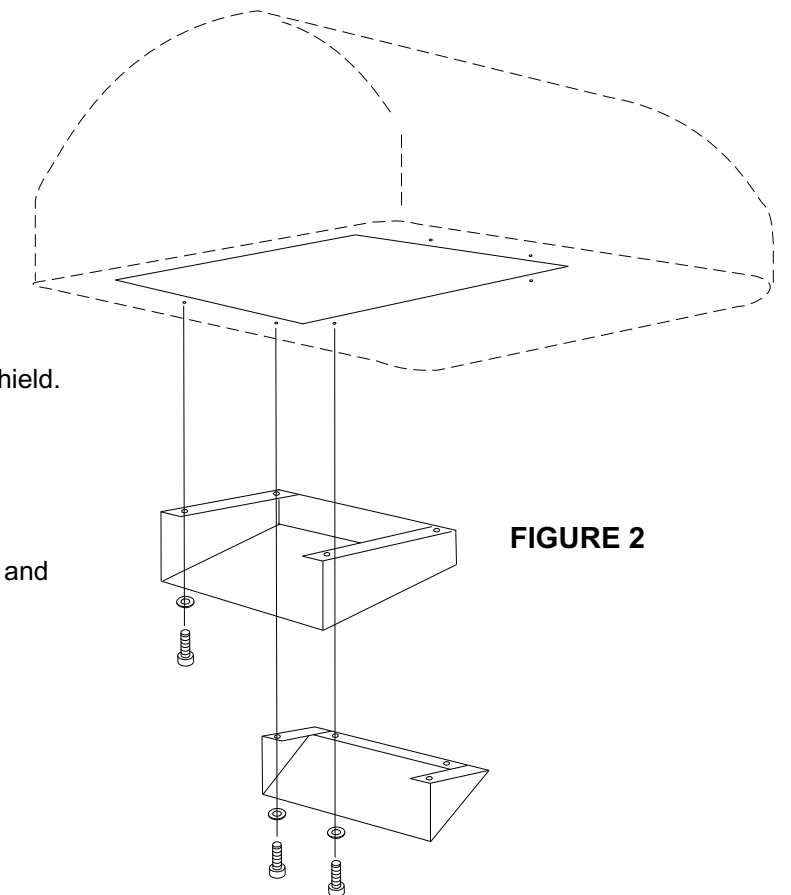

FIGURE 2



LSI LIGHTING SYSTEMS

10000 Alliance Road ♦ Cincinnati, Ohio 45242 ♦ (513) 793-3200 ♦ Fax (513) 984-1335 ♦ www.lsi-industries.com

Installation Questions?
Call LSI Field Service Department at:
1-800-436-7800 Ext. 3300 Fax: (513)793-0147



LSI LIGHTING SYSTEMS

10000 Alliance Road ♦ Cincinnati, Ohio 45242 ♦ (513) 793-3200 ♦ Fax (513) 984-1335 ♦ www.lsi-industries.com

Installation Questions?
Call LSI Field Service Department at:
1-800-436-7800 Ext. 3300 Fax: (513)793-0147